

INVESTIGATION INTO THE EFFECT OF THE 30 KM/HR COUNTERMEASURE;
ORGANISATION AND APPROACH

Lecture presented at Helsinki University, Helsinki, Finland,
May 16th 1985

R-85-41

J.H. Kraay, research sociologist

Leidschendam, 1985

Institute for Road Safety Research SWOV, The Netherlands

Introduction

It is a well known fact that most traffic and transport problems in the last 20 years are mainly caused by the ever increasing ownership and use of motor cars.

The crux of these problems is that car traffic requires more and more space, while creating unsafe conditions for slow-moving traffic, making people aware of traffic unsafety and unfavourably affecting the environment. All these problems have the strongest impact on towns, due to the heavy concentration of both driving and parked cars on the sparsely available space. The traffic function has a suffocating effect on other urban functions, mainly endangering the most vulnerable groups of road users: the pedestrians and cyclists (Table 1).

Experimental policy

Dutch authorities recognised these problems since many years. In the seventies various governmental reports announced experiments for reclassification and reconstruction of urban areas and streets with the goal to improve the quality of life for the people living there.

One of these experiments, and undoubtedly the most ambitious as regards scope and organisation, was the Demonstration project "Reclassification and reconstruction of urban areas", which has been carried out in the municipalities of Eindhoven and Rijswijk. According to this project the urban areas have been reclassified into more clear traffic zones and residential areas, the reallocation of these areas being effected by various packets of countermeasures.

As early as in 1977 a governmental decree granted financial aid to municipalities for the execution of experiments with the special aim to improve the road safety of pedestrians and cyclists.

The knowledge available at present and the effects that can be expected

In order to improve the safety and quality of life of people living in residential areas or have there to do something, countermeasures for

controlling the traffic circulation and for realising a suitable traffic behaviour have to be implemented.

Countermeasures controlling the traffic circulation may include:

- the closing down of residential streets at the junction with the through-roads:
- the closing down of streets within the residential area by creating cul-de-sac type and loop streets;
- the combination of the above measures;
- the creation of one-way traffic systems.

Countermeasures aimed at achieving suitable traffic behaviour may include

- speed-reducing measures, like the construction of traffic humps, installing obstacles, shifting the road axis, narrowing the streets;
- developing residential areas into "woonerfs";
- implementing a 30 km/hr speed limit.

It is an internationally accepted rule that motorised traffic has to drive slowly in residential areas. The Parliament of the Netherlands accepted this rule as well. Moreover, the maximum speed of 50 km/hr was found much too high for residential streets within built-up areas. Traffic is too fast in such streets, increasing unsafety and deteriorating the quality of life of the residents. The parliament invited the Minister of Transport to amend the traffic law in such a way that municipal authorities may be empowered to reduce the maximum speed where necessary.

Since April 1st 1983, it is possible in the Netherlands to institute a maximum speed of 30 km/hr on certain roads within built-up areas. Since January 1st 1984, it is also permitted to indicate this speed limit by zone boards. This countermeasure is the consequence of the idea that the compulsory 30 km/hr speed limit has a favourable effect on traffic safety.

Accident data collected on a national level permit the conclusion that traffic problems within built-up areas mainly involve the slow-moving traffic, conflicting with motorised traffic. As regards the traffic safety in residential areas, no data referring to the entire country are available. According to local studies:

- accidents in residential areas are not concentrated on certain loca-

tions ("black spots"), but are scattered over the entire district as a whole;

- black spots (if any) occur in streets with an "access" function;
- the victims of accidents are in the first place old people, pedestrians and cyclists;
- traffic unsafety is greater in old districts than in the new ones; this is most probably due to a combination of various factors: differences in land use, densely built houses, conditions of dwellings, the composition of the population and the general picture of traffic.

After these preliminary observations, the question arises: which speed limit can still be safely accepted in residential areas? Up till now, the relationship between the driving speed and the risk of accidents in residential areas has not been studied. We know, of course, that an emergency stop at a 50 km/hr speed requires a braking distance of about 33 metres. We cannot be sure, whether this is acceptable if the driver can be confronted at any moment with children kicking the ball in the street or crossing over it. At a lower speed the reduction of the braking distance is out of proportion. Thus, for example, at a 30 km/hr speed the braking distance is not more than 16 metres. An investigation carried out into the relationship between the speed of collision and the severity of an accident proved that pedestrians hit by a car at a 30 km/hr speed, as a rule, sustained severe injuries. At a collision speed between 30 and 50 km/hr injuries can already be quite serious, while at speeds above 50 km/hr injuries are highly perilous, even lethal. All these data indicate that the speed of collision has in any case to be kept well under 30 km/hr.

In reducing the maximum speed in residential areas, the main concern is for the safety and comfort of pedestrians and cyclists. However, in streets of mixed functions the interests of motorised traffic have to be taken into account as well.

The speed of motorised traffic in residential streets can be reduced by legal countermeasures, for example by the institution of a general speed limit in residential areas. However, researchers working in the "Tempo 30" campaign, launched in the Federal Republic of Germany, found such countermeasures not very effective.

For the police it is quite impossible to enforce such a speed limit on a large scale. Speed limits on specific locations (for example in the neighbourhood of schools) and at certain times (at the beginning and the end of the school time) are more promising. This was proved by experiments in Norway. The effect of countermeasures on traffic behaviour can be intensified by explaining the reason of the speed limit. However, according to several studies, physical countermeasures have a greater influence on traffic behaviour than the aforementioned. Physical countermeasures can be supported by law, education, information and training. There are various execution forms of physical countermeasures, which can be applied individually or in combination with other ones, for example, traffic humps, sharp bends, narrow road sections, shifting the road axis, restricting the driver's field of vision. To be really effective, such physical countermeasures must be given a rather conspicuous design. However, there are other aspects as well, which may decide the success or failure of such countermeasures. From all physical countermeasures, it is the traffic hump which enjoys the greatest attention. In the past years various types of hump constructions have been tested, but since 1979 there is in the Netherlands an SVT-recommendation (SVT=Study Centre for Traffic Engineering) for an optimal design (Figure 1). However, the location of the humps the street is still a object of discussion.

It is worthwhile to mention that an investigation carried out in the Federal Republic of Germany established a relationship between the car speed and the situation of the traffic humps, both as regards average speeds and the 85% speed value. The graph indicating this relationship proves that in case of a great distance between the humps, the average speed is about 45 km/hr, while in case of a 85% value this is about 57 km/hr. In case the humps are arranged at intervals of 50 m, an average speed of slightly under 30 km/hr can be expected, with a 85% value of about 35 km/hr (Figure 2).

In England accident investigations have been carried out to reveal the effect of traffic humps. The hump structures applied resemble those recommended by SVT. In streets, provided with humps and adjoining inter-sections, the number of injured persons was reduced by 61% (Table 2). In England investigations were also effected to study the behaviour of

traffic participants. These investigations disclosed that the vehicle intensities in streets provided with humps were reduced by 37% and the average driving speed by 43%. It is evident that the reduction of the number of injured people can be ascribed to the combined effect of both factors.

The effects of traffic humps were studied in the Netherlands as well (Amsterdam and Rotterdam). According to the study results, humps have a favourable effect both on the average speed of various categories of traffic participants (including the cyclists) and also on the range of speeds.

Finally, studies were carried out in England to find out how people experience traffic. The polls included also questions about opinions on the traffic humps. More than 80% of the questioned residents were content with the humps and found them useful. However, only 55% of the interviewed car drivers were of the same opinion, although 71% admitted that they serve a good purpose. In streets with humps, the noise nuisance was abated as well, partly due to the less intensive traffic and partly to the lowered car speed.

Thus, all in all, it can be stated that the 30 km/hr speed limit (actually a combination of speed limiting measures and traffic signs) can be expected to reduce the number of traffic accidents on the one hand, while on the other hand the reduction of collision speed will lead to accidents causing less severe injuries.

The goals of the 30 km/hr speed limit

The goals to be achieved by the 30 km/hr speed limit also relate to ideas about the long-term design of residential areas.

The 30 km/hr speed limit is one of basic principles of the policy aimed at creating in the future, within built-up areas, two categories of roads: so-called traffic streets and residential streets. The speed limit will apply to residential areas, with the characteristic traffic feature, that motorised traffic must give priority to the habitat function of the area and its environment.

The guidelines issued by the Secretary of State of Transport in the Netherlands indicate the conditions, the institution of such speed limit has to comply with (directives as regards applicability, conditions). The basic principles of the speed limit countermeasure can be formulated by clearly segregating the residential areas from the traffic areas and by the application of guidelines.

Recent publications of the Ministry of Transport contain the following general goals, which are of importance for the 30 km/hr speed limit as well:

- promoting the mobility of certain groups of residents, like disabled persons, older people, children, pedestrians, cyclists;
- promoting the use of public spaces by the slow-moving traffic (e.g. more playing children in the street);
- maintaining and improving the accessibility of places of destination in residential areas for the residents and service traffic;
- reducing the number of traffic accidents in residential areas, mainly as regards cyclists and pedestrians;
- mitigating the residents feelings about unsafety;
- reducing the irritating effects of traffic in terms of noise, stench, vibrations, sneaking traffic, improper parking.

For implementing the 30 km/hr speed limit, the Secretary of State of Transport in the Netherlands formulated the following goals and requirements:

- (1) The character and condition of the road must be such, and/or such speed reducing provisions must have been installed, that a maximum velocity of 30 km/hr is a logical consequence of these circumstances.
- (2) Insofar as motorised traffic is concerned, the road may have only a function for traffic having a destination or a point of departure on that road in the immediate vicinity of the former. This holds true as well for the roads or parts of roads situated within a 30 km/hr zone.
- (3) A maximum velocity of 30 km/hr on roads being part of a route of the public transport is only then permitted if the appropriate function thereof is not considerably impaired.
- (4) The impression that the road or parts thereof concerned are part of a "woonerf" must be avoided.

(5) The speed reducing provisions, as mentioned above (1), may not hinder motor vehicles used by the police, ambulance etc. and delivery vehicles.

(6) The provisions mentioned under (1) must be duly illuminated so as to be clearly visible during the hours of darkness.

(7) The provisions mentioned under (1) may not constitute a danger if passed with the permitted velocity of 30 km/hr.

It is hoped that in addition to the legally enforced 30 km/hr speed limit the aforementioned requirements will be complied with, which will have a positive effect on mobility, speed and traffic safety.

Other problems the authorities are interested in with regard to the evaluation and goals of the 30 km/hr limit are:

- whether the road controlling authorities (municipalities) will be capable of handling the regulation;
- whether the regulation can be adapted to certain criteria of the areas like road constructions, shaping, optimum size, etc.;
- whether an optimum formulation can be found for the concept "habitat" area (size of the area, traffic performance, acceptance of a certain traffic behaviour, level of provisions, etc.).

Possibilities of investigations

Within the framework of the experimental policy of Dutch authorities, it will be possible to finance (at least partly) experimental projects and adequate supporting investigations as well. It is envisaged to establish the 30 km/hr speed limit in about 15 residential areas in the next two or three years in order to evaluate the effect of this measure on traffic safety. A sum of about 150.000 Dutch guilders is made available for the investigation per each experiment. Evaluations are necessary, because there can be differences in the diverse residential areas as regards the accidents actually occurring, the driving speed of vehicles and the speed reducing countermeasures, which already have been implemented.

Situations, where (relatively) important effects of the countermeasure on mobility, speed and safety can be expected, will of course attract the greatest interest. This means that residential areas of (relatively) unsafe character with speed limits above 30 km/hr and with no speed lim-

iting measures as yet, will have to be included in the investigation. Residential areas, which are deemed safe, even with a speed limit above 30 km/hr, yet without restricting measures, can also be studied, because it can be expected that the 30 km/hr speed limit will have a marked effect on the attitude of residents towards traffic.

Residential areas where the 30 km/hr speed limit is already in force and physical measures are there installed, will not be included in the investigation, because no further effects on mobility, speed and traffic safety can there be expected.

If 15 experiments will not be enough to solve all the problems, it will be possible to carry out more experiments. At the same time we shall be able to study some special problem situations in an experiment as well, like situations related to schools, old people, etc.

Approach to the investigation

The Road Safety Directorate (DVV) of the Ministry of Transport selected 15 residential areas out of about 25 candidates. The basic idea was to experiment with rather large residential areas.

The concept: residential area

How can we define this concept? The term "residential" area is used in contrast to "traffic" area. These concepts refer to the dominating functions of public spaces: sojourning or traffic. The arterial roads constitute the traffic areas, while the residential areas are between the arterial roads. The concepts: traffic area and residential area were first mentioned in a Dutch report "Traffic livability in towns and villages". According to this report, traffic livability is expected to be improved by dividing the public spaces in a rather stringent manner, into traffic areas and habitat areas. However, the division of an urban space into not more than two categories, with clearly identifiable characters, seems to be impossible. Streets have long since a mixed function. Moreover, such a division is also undesirable. Streets with only sparse traffic have then to be included in the category: traffic area, and have to be structured accordingly. The habitat function of such streets, which is just as important as the traffic function, will then be unfairly neglected. This

problem can be solved by appointing some streets as "main access streets" to the residential area. The design of such streets with mixed function must, in any case, ensure the full protection of vulnerable road users (pedestrians, cyclists). Thus, we ask again how can we define the concept: residential areas? A clear definition involves certain problems, caused by the various (planned and unplanned) patterns of urban development. The main problem is the demarcation of the residential area's boundaries and the establishment of the areas' principal functions. In the last decades, residential areas came into being in a more or less characteristic manner. Quite often there is a relationship between the building complexes; the traffic network displays a recognisable structure of access roads and residential streets; the main function of the area is to house people. In such situations it is not difficult to give a clear and unambiguous definition like the following: a residential area is a built-up space comprising exclusively accommodations for people and facilities, which are necessary for the everyday life of the inhabitants, like schools, playing grounds, shops, small-scale business. The boundaries of such areas can be formed by arterial roads or other barriers (water, green belt).

In the past residential areas have developed otherwise than in the last decades. Old-time residential areas grew around the town centre, on locations along the streets passing through the town. It is not an easy matter to define the boundaries of such older areas and it is not quite sure, whether the arterial roads as they exist today, may or can be regarded as boundary lines. By accepting such boundary lines we would stabilise a situation, which is in sharp contrast with our up-to-date ideas about woonerf and the slogan "50 is too much!".

In the Netherlands a comprehensive definition of the concept residential area is not possible, because various types of residential areas developed in various periods of time. For this reason we shall confine ourselves to the following indications:

- the main function of a residential area is to house people, while providing facilities for the primary needs of everyday life, like schools, shops, services, small-scale industrial enterprises, etc.
- the type of buildings or the structure of the residential areas is, as a rule, of a homogeneous character;

- preferably there should be no arterial roads for the through-traffic and not many facilities, which would have a negative effect on the district's living sphere; main access roads are an essential part of the district, but they present the problem of fragmentation, which is inevitable when the urban area is divided into traffic and habitat areas.

In spite of the difficulties involved in defining the concept residential area for research purposes efforts are being made to establish a typology of the residential area. According to a literature study the delimitation of neighbourhoods and districts can take place by an analysis of the concept of such areas. The study indicates three approaches to such analyses.

In the first approach the activity pattern of a group of people is investigated. In this way an area, which is frequented by people quite often, can be delimited from areas, visited less intensively. Grünfeld defines by this method the residential concept in the following manner: "the total space used by an individual person or by a group or collectivity of persons regularly at a given frequency for his/her/their activities and communications".

The second approach suggested is of a social-psychological character. It consists of noting and analysing pictures of spatial units, as experienced by people.

The third approach is focused on the morphological and/or statistical criteria of spatial units. Areas with buildings and/or population of homogeneous character or which are separated from each other by distinct boundaries, are accordingly categorised.

For the time being, it is not completely clear, which of the three approaches is the most suitable for traffic safety investigations.

Selection criteria for investigating 30 km/hr speed limit areas

At present it is not yet known to what extent the selected residential areas display identical or different criteria. Neither is it clear which criteria are of importance in relation to traffic safety and consequently should be varied in the investigation design.

In studying reference literature the following criteria have at least to be taken into consideration:

- The size of the area

The size of the area implies various consequences with regard to traffic safety. In a large residential area the traffic participants are for a longer time on the way to their destination. This may lead to an over-estimation of the travelling time, which in turn may irritate the drivers, inciting them to drive faster, thus transgressing the 30 km/hr limit. This example may indicate that in large residential areas car drivers have relatively more conflicts with the rest of the traffic than in smaller districts.

It is also possible that larger residential areas are provided with more facilities for the residents than smaller ones. In this connection we mention shops, schools, small workshops, public parks, etc.

All this has consequences for locomotion within the area, or inwards to and outwards from it, for example if there is a big shopping centre and a post office as well.

Recently developed residential areas are more generously dimensioned than the older ones. According to reference literature, older residential districts are less safe than the new ones. This can be caused by the different use of land. For example, in older areas more buildings have a mixed function: the shopkeeper's dwelling is above his shop. Also the buildings are more closely built to one another, depriving children of playing ground, while other activities of the residents have to take place in more restricted areas as well.

- Population structure

It is a well-known fact that in densely populated areas and in areas with a great number of young pedestrians, traffic unsafety is relatively high.

- Traffic structure

As regards traffic structure the following conclusions can be drawn from relevant literature: residential areas with an undifferentiated road net, school routes, many four-way intersections, many side streets per road-length km, long streets, narrow streets, involving complex traffic situations, streets for the through-traffic, scarce parking places for the cars, a great number of cars parked in the streets, busy traffic, have a negative effect on traffic safety.

On the other hand, in residential areas with a far-going segregation of traffic categories (segregation of bicycles and mopeds from cars), with cul-de-sac type and loop streets and closed-down streets, traffic safety is on a much higher level.

It is evident that the three main criteria: the size of the area, the structure of population and of traffic, are in relationship with one another. Since, however, the character of such relationships is not yet cleared up, we shall keep the aforementioned criteria apart.

The aforementioned considerations also imply that the areas to be studied must display sufficiently different criteria. Only a great number of variables will permit an insight into the causes of differences in the traffic safety aspects of the various areas. In case the criteria of the selected fifteen areas are not sufficiently diversified, more areas will have to be studied in order to be able to assess the effectiveness of the countermeasure on the basis of the variables. This also implies in fact the necessity of a before-study for establishing the relationship between the criteria to be distinguished.

As regards selection criteria, it is of importance that in the period before the investigation, cars, as a rule, drive faster than 30 km/hr. Otherwise the evaluation of the 30 km/hr speed limit will be less striking.

To sum up: the areas to be investigated have to be diversified as regards the criteria of the areas involved and the countermeasures taken.

The scope of investigation

The goals to be achieved by the 30 km/hr speed limit are expected to bring forth two important and direct effects, namely the reduction of the speed of motorised traffic and the elimination of sneaking traffic.

In view of the area-wide character of the countermeasure, the ideas about the speed behaviour of drivers in the whole area must be expressed in terms of maximum, minimum and average speeds, standard deviations and 85-percentage values.

It is assumed that in most areas there is an improper category of traffic: the sneaking traffic. It is hoped that the countermeasure to be taken will put an end to this category of traffic, driving through streets from which cars are actually banned.

A lower driving speed of the motorised traffic in combination with the

elimination of the sneaking traffic, will have a beneficial effect on the traffic safety, mainly as regards the vulnerable road users.

In view of the limited scope of accident investigations in small-scaled evaluation studies, other data which in some way are related to traffic safety, should be collected as well. In other words: in addition to accident investigations, complementing investigations into the causes of accidents should be carried out. The accident figures proper gives no information about them.

Complementary data refer to behaviour aspects, which are supposed to have something to do with traffic accidents, like near-misses and conflicting behaviour with regard to other traffic participants.

Such data can be included in traffic situations where, as a result of the 30 km/hr speed limit, critical circumstances are developing, like for example in transition zones between residential areas and traffic areas. Also local problems, for example in connection with schools, can be considered for evaluation investigation by means of conflict observation techniques.

From this point of view, data obtained by opinion polls are not really complementary data, since from Dutch studies no relationship with traffic accidents can be established.

Authorities may have other reasons for being interested in the way people are aware of traffic and traffic safety as a consequence of the counter-measures taken. Opinion polls can reveal general feelings, thoughts, arguments about certain subjects, but the reliability of the answers obtained and the validity of conclusions drawn from them are still a matter of discussion.

Selection of investigation areas

As mentioned above, the Road Safety Directorate DVV of the Ministry of Transport already selected 15 residential districts from 25 candidates (Table 3).

The Road Safety Directorate laid down the following selection criteria:

- The size of the area

As mentioned earlier, the aim was to select the possibly largest areas.

However, the comparison between the criteria of smaller and larger areas is important as well. For this reason both small areas (+ 20 ha) and larger ones (up to + 100 ha) will be covered by the investigations.

- Regional spreading

On account of the demonstration character of the entire campaign, the projects will be spread over the whole country.

- The structure of the district

Districts of various structure were chosen. The study of areas with mixed traffic categories (excepting pedestrians) and with incidentally segregated bicycle traffic, will be emphasized.

- The buildings of the district

Various modes of building and building densities (low-rise and high-rise buildings), etc. will be investigated.

- The activities of the residents in the district

Districts of diversified activities were preferred.

- The countermeasures

The proposed countermeasures have to be cheap, simple, effective and appropriate to investigation.

Questions of the investigation

On the basis of the aforementioned goals and areas of special interest, several investigation questions have been formulated which are in a close relationship with the countermeasure.

A. Traffic

1. Has the number of residents (mainly of the so-called vulnerable road users, like disabled persons, old people, children, pedestrians, cyclists) walking in the streets, increased?
2. Is the number of pedestrians or cyclists going shopping within or outside the residential areas higher than of those using the car?
3. Idem as regards the traffic commuting between home and working place?
4. Could the through traffic (sneaking traffic) effectively be banned from the residential area?
5. Are there no negative effects on the travelling times and comfort of public transport (if operating in the area)?
6. Are offices, workshops, shops, easily accessible, both for residents and the necessary deliveries and services?

7. Did the countermeasure modify in any way the choice of route within the districts?

B. Traffic behaviour

1. Could the speed of motorised traffic (including mopeds and excluding bicycles) be reduced to an average speed under 30 km/hr?
2. Could the mutual traffic behaviour (in terms of anticipation, manoeuvres, crossing the street, conflicts) of traffic participants be improved?
3. Is the pedestrian sufficiently protected? (No hindrance in longitudinal and lateral direction, no conflicts with the motorised traffic). Which are the consequences of all this as regards the segregation of traffic categories?
4. Has the bicycle traffic to be segregated from the motorised traffic, if speed-reducing provisions are installed in the area?
5. Is the through-traffic on the surrounding road net in any way hindered by traffic from the residential area?
6. Are public spaces more intensively used by pedestrians and cyclists?
7. Are there more conflicts at the entry and exit of the district, between in and out going traffic and the through-traffic? (Priority aspects may play here a part!).
8. Is there sufficient manoeuvring space for emergency services (ambulance, police, fire brigade) and heavy traffic?

C. Accidents

1. Are there less traffic accidents both in absolute and relative sense and as regards place, time and circumstances?
2. Are there more traffic accidents in the transition zones between residential areas and traffic areas?
3. Are there more traffic accidents on the surrounding road net (traffic area), for example due to banning the sneaking traffic?
4. Are there less traffic accidents involving the vulnerable road user categories?
5. Could the severity of traffic accidents be mitigated?
6. Are there no extra accidents, caused by the obstacles, installed for the sake of the countermeasure (both in daytime and nighttime)?

D. What are the experiences of the residents as regards traffic and traffic safety?

1. Is there a positive effect on the feelings of unsafety (if any) of the residents and traffic participants?
2. Did the countermeasure reduce in any way the nuisance caused by fast traffic in terms of noise (smell, vibrations), improper parking?
3. Has the countermeasure an irritating effect on road users, due to longer travelling times, frequent encounters with speed-reducing obstacles?

For the evaluation investigation a choice must be made from the great number of questions, in the first place in view of some limiting conditions, for example of financial character.

Execution of the investigation

On the basis of the proposed scope of the investigation and the formulated questions, the actual evaluation investigation will consist of accident investigation, traffic behaviour investigation and experience investigation.

- Accident investigation

The accident investigation aims at determining the effects of the 30 km/hr speed limit on traffic safety, expressed in terms of changes in the number of traffic accidents.

Two variants of investigations are recommended:

A. An analysis of all accidents, which involved injuries in a before- and after-period. In the Netherlands, accident data can easily and systematically be obtained by the Road Accidents Recording Office VOR. This is a central institution, recording via a coordinate system all accidents, according to the exact location of the accident. A before-period of 5 years and an after-period of 3 years are envisaged.

B. An analysis on the basis of police-files of all accidents, including also those with only material damage. This analysis permits a qualitative description of problem locations, while also providing more information as regards the circumstances of accidents.

In this investigation a distinction will be made between the experiment area (where the countermeasure will be enforced), the surrounding main road system (as "influence" area), while the rest of the municipalities will serve as a sort of estimating control area for trend effects.

The question, whether the experiments should be extended over all the twentyfive candidate municipalities is still under consideration.

More experiments would of course permit finer distinctions in the analyses, for example with special attention to the situations at the entry and exit zones of the experimental areas and to problems caused by speed reducing obstacles, etc.

- Traffic behaviour investigation

This investigation covers the speed behaviour and conflict behaviour of traffic participants.

A. Speed behaviour. Since an important goal of the project refers to influencing the speed behaviour of motorised traffic, an extensive measuring programme has to be set up in order to get a clear picture of the speed behaviour over the entire experimental areas. For this purpose measurings obtained by following persons in the traffic, furthermore radar or video measurings on fixed locations can be used.

In addition to establishing speeds at several fixed locations (where sophisticated speed-reducing obstacles are provided) by means of a radar system, endeavours are being made to get a "speed picture" of the entire area.

For this purpose a system has been developed using a so-called "floating car", following cars criss-cross over a given area and establishing the car speed per each road stretch, based on several criteria (Figure 3). The measurable criteria include: the average speed, the maximum and minimum speeds, the 85-percentage value, according to the road stretch and route, and fuel consumption.

B. Conflict behaviour. In general, the conflict method is applied to find out those critical aspects of the road users' behaviour with regard to his surrounding, which are relevant for traffic safety.

The conflict method is based on the assumption that traffic unsafety becomes more dangerous with increasing aggressiveness of the interactions between traffic participants, leading, in turn, to more accidents.

In addition to these applications, mainly intended for establishing the volume of traffic unsafety, there are reasons to hope that by means of various adequate techniques it will be possible to analyse traffic safety aspects on the basis of conflicts, in order to reveal the causes of unsafety.

The conflict method is already applied in practice in several countries. In view of the favourable results of the international calibration study held in Malmö, it is the intention of Dutch authorities to apply the method in the Netherlands as well.

In investigations using the conflict observation technique, it is possible to record changes in the traffic process, caused by a countermeasure, the records giving indications of the effect of changes on traffic safety.

Depending on the problems involved there are two practical possibilities of applying in the Netherlands the conflict observation techniques developed up till now.

- Manoeuvre behaviour as the consequence of, for example, changes in the design of traffic-technical countermeasures. The video technique developed by the Dutch Institute for Perception IZF-TNO (Van der Horst) is extremely suitable for carrying out this method.

Such video observation technique can be used, for example, in studying manoeuvrability and conflict behaviour in traffic as regards speed reducing obstacles or the possibility of segregating moped riders and cyclists from the rest of traffic and the complications, which could be caused by such segregation.

- Problems implicating school children in the surrounding of the school. Such situations can be studied by the technique, developed by the Netherlands Institute for Preventive Healthcare NIPG-TNO (Güttinger) especially for the observation of young pedestrians.

- Problems involving various categories of traffic participants on certain locations (for example, intersections) can be studied by means of conflict observation techniques, as applied in Sweden, Finland, the Federal Republic of Germany, France or England. Experiences gained in applying the Swedish technique to the Demonstration project "Reclassifi-

cation and reconstruction of urban areas" in the Netherlands are very promising.

For the last mentioned problem-complex there is, as yet, no technique available in the Netherlands. Such technique can best be taken over from another country, where it has already been applied with good results, in this way saving time and money.

Based on experiences gained in the Demonstration project "Reclassification and reconstruction of urban areas" and the results of the Swedish technique in the international calibration study in Malmö, preference should be given to the latter. In the meanwhile extended investigations with diverse applications of the technique have been carried out in Scandinavia.

In July 1983 observers have been trained in the Netherlands according to the Swedish technique so that at present three conflict observation techniques are available, which can be used, depending on the problems and questions to be solved.

In the following some more information about the two Dutch techniques will be given.

At the Institute for Perception IZF-TNO a method has been developed for a quantitative analysis of video recordings in a semi-automatic way.

The vehicle movements, recorded on video-cassette, are analysed quantitatively to describe their behaviour in terms of course, course changes, speed, speed change and measures for the interaction with other road-users, for example time-to-collision (TTC). The quantitative analysis consists of selecting the positions of some points of the vehicle on a video still. By means of transformation rules, positions in the plane of the picture can be translated to positions in the plane of the street. By differentiating successive positions in time, the speed of the vehicle can be obtained. The selection of one picture from every six (one picture/0.24 s) seemed to be a reasonable compromise between accuracy and length of analysis time.

A transformation from video coordinates to street coordinates takes place. This transformation offers the great practical advantage that nothing has to be known about the position and orientation of the camera. All infor-

mation is included in the way in which the four points on the street are projected on the video plane. On the street, only the distances between the points have to be measured.

The following example illustrates the TTC measure. In a situational map of an intersection the courses of a car coming from the minor road and two cyclists on a cycle track are plotted (Figure 4). Each point gives the position of a given point of a vehicle at successive time intervals, here 0.24 s. The plot in the bottom corner gives the TTC curve of the interaction between the car and cyclist 1. The car driver did not give right of way to the cyclists. Cyclist 1 had to stop (points close together), while cyclist 2 rode behind the car. The minimum value of TTC is 0.7 s. Cyclist 1 had to take a strong evasive action to avoid a collision. For the calculation of TTC, Figure 5 gives the simplified situation at time t . Vehicle 1 and vehicle 2 are approaching each other. Assuming that from the moment t no changes in speed occur, for each vehicle a straight line is estimated through the current point (P) and three preceding points. The intersection of the two lines, point S, is determined. Then, the decision is made whether the vehicles are on a collision course or not, taking into account the dimensions and speeds of both vehicles.

At the Netherlands Institute for Preventive Healthcare NIPG-TNO a conflict observation technique has been developed. The main objective in developing this technique was to have a conflict observation technique which can be used in various urban planning designs to establish road users' behaviour e.g. evaluations of whole areas like the "woonerf". The research was concentrated on children, as they are the most intensive users of the residential area.

The technique contains both personal and sector observations.

In personal observations, a child is followed for a maximum of 30 minutes. In the event of an encounter with a road user, this is characterised by reference to a number of variables. If a child leaves the research area (by going indoors somewhere or leaving it) observation stops. In the case of sector observations, a number of sectors are observed every day during a fixed period. Each encounter during the observation period is recorded in terms of a number of variables. Sectors observed in this way are: areas near elementary and infants schools in neighbourhoods and entries and exits for neighbourhoods.

In this technique an encounter is defined as a reaction by a party, or both of the parties involved in a traffic situation towards the other, with a distance of 20 metres or less between those involved.

The various types of encounters are defined as serious conflicts, conflicts, intensive contact-conflict, contact-conflict, intensive contact and contact between pedestrians and other road users (Figure 6 and 7).

- Experience investigation

According to some theories there is a causal relationship between the opinions, ideas and experiences with traffic safety, the alleged behaviour and consequent traffic behaviour of traffic participants and the occurrence of accidents.

However, referring to the Demonstration project "Reclassification and reconstruction of urban areas" the impression is that there is no causal relationship between the aforementioned opinions, ideas and experiences with traffic safety, alleged behaviour on the one hand and objectively measured traffic behaviour on the other hand.

This leads us to the conclusion that the required information must be obtained as far as possible from objective measuring data instead of data obtained by less reliable opinion polls.

On the other hand, authorities are with some reasons interested in the subjective traffic experiences of traffic participants.

Thus, the experience investigation in connection with the 30 km/hr speed limit experiments cannot be restricted to establishing in a global manner the opinions of residents and traffic participants as regards the effects of measures against traffic unsafety and over-intensive traffic.

The experience investigation covers several aspects of the 30 km/hr speed limit measure, strictly from the viewpoint of the residents (both as residents and traffic participants in their area), related to the actual behaviour of the persons involved and differentiated according to various resident-categories.

The residents are interviewed about the following aspects:

- are the envisaged countermeasures, including legal behaviour rules and their reason sufficiently known?
- are the residents willing to follow the behaviour rules and (after

implementation of the countermeasures) accept the inconveniences that may be caused by them and confusions with other traffic systems like those realised in woonerfs?

- experiences as regards "sneaking" traffic and changes in this respect after the implementation of the countermeasure;
- experiences as regards the speed of motorised traffic in the area and changes in this respect;
- awareness of traffic safety/unsafety in their area (in general and on certain special locations) by the traffic participant proper (under various circumstances) or on behalf of other persons (children); after the implementation of the countermeasure the changes caused by it;
- which are the experiences as regards nuisance, hindrance caused by the traffic (noise, too many parked cars); are there changes after implementing the countermeasure?
- which consequences have the countermeasures as regards the accessibility of certain places in the district, for various categories of residents, mainly older people and children, and as regards the mobility of these categories?
- which are the side-effects of the countermeasures, for example on the choice of transport means, the routes through the area and the functioning of the public transport system?

It is not claimed that this survey of aspects is complete. Moreover, for practical reasons, choices will have to be made and some aspects will have to be emphasised. The formulation of the questions will still further be improved, with greater emphasis on the personal experience and personal situation of the questioned persons (for example as regards the use of transport means) and special situations in various areas (in view of mixing and segregating various traffic categories).

The before-investigation consists of two phases:

1. There will be carried out a global and extended investigation in all selected areas, for example by means of opinion polls in writing, which will provide comparable data concerning the above detailed aspects.
2. An investigation "in depth" in some areas, involving live discussions with residents or groups of certain categories of residents, over some special problems indicated in the given survey, which form bottlenecks in

the execution of the countermeasures or which are specially emphasised in them. The areas, where "in-depth" investigations take place, have to be selected on the basis of the results of the area-wide investigation and of information concerning the areas and the envisaged (implemented) countermeasures, which at that time is already available.

In principle, the same phases can be applied in the after-investigation as well.

An example of the 30 km/hr speed measure in the area "de Vliert"
('s Hertogenbosch)

The residential area "de Vliert" is a part of 's-Hertogenbosch, a town in the middle of the Netherlands. It has a surface area of 11 ha, and includes 275 dwellings with 900 residents. There are shops scattered over the entire area and four schools.

The streets are straight-lined with lengths between 200 and 400 m. The road profiles are of generous dimensions: with carriage way width between 5.50 and 7.50 m and pavements between 2.00 and 5.00 m.

The course of most streets is indicated by a row of trees on one side, intensifying the through-going character of the street. The intersection planes have a copious design, achieved by widely curved streets. The carriageways are coated with asphalt. Such surfaces, together with wide road profiles, will prompt the drivers to drive at relatively high speeds.

This residential area is the last but one in the town, as regards traffic unsafety, with an accident quotient of 1.09 (number of accidents per 10 residents); while the average accident quotient of all neighbouring areas is not higher than 0.35.

The dominating feature of accidents is: disregarding the right-of-way rule on intersections.

According to the city authorities the picture of accidents (Table 4) is determined by the following factors:

- the presence of through-traffic within the residential area;
- high driving speeds, which are also provoked by the wide streets;
- intersections are not clearly visible due to the through-going character of the streets, the green scenery created in them, and the presence of parked cars.

The planned countermeasures will improve the visibility at intersections by:

- intensifying the visibility of intersections through installing beacons and markings;
- creating narrow street sectors in combination with shifted street axes in the surrounding of intersections;
- raising the intersection planes.

The driving speed of cars approaching to the intersection will be influenced by:

- creating traffic humps and shifting street axes on road planes;
- by legally enforcing a 30 km/hr speed limit through boards indicating the speed limit zones.

The sneaking traffic will be eliminated by establishing one-way-street systems and closing down certain streets.

The total costs of this project amount to 265,000 Dutch guilders. This sum includes engineering and land development works, power and water consumption, value added tax, designing costs and general expenses of public works.

The annual maintenance costs are estimated at 1,700 Dutch guilders.

Enquiries about sneaking traffic and accident prevention disclosed that there are certainly some streets frequented by sneaking cars and displaying at the same time high accident concentrations.

It is an often voiced opinion that sneaking traffic is one of the main causes of accidents in residential areas. This project makes it possible to study such opinions in detail.

Investigations proved that reconstruction measures (both simple and more radical ones) are effective means for banning sneaking traffic from residential areas. The woonerf is the most convincing evidence of the effectiveness of such measures.

However, it is less evident that sneaking traffic can be banned by reducing the speed of motorised traffic through design measures. In spite of this, it is obvious that in addition to eliminating sneaking traffic, lower driving speeds will have a positive effect on reducing the number of traffic accidents and on mitigating their severity.

The specific investigation questions for the "de Vliert" project are formulated as follows:

1. Will design measures result in a marked reduction of the volume of sneaking traffic?

For this purpose a number-plate investigation will be carried out both in the before- and the after-period.

2. Will design measures reduce the speed of motorised traffic in the whole residential area?

For this purpose a speed control will be carried out both in the before- and the after-period by means of a floating car.

3. Will design measures and a marked reduction of sneaking traffic in streets where in the before-period sneaking cars were often observed, lead to lower driving speeds in these streets?

For this purpose a comparison will be made between streets which, during the before-investigation, were frequented by sneaking cars, and streets with no sneaking traffic in the same period. These data form a sub-set of the investigations indicated in points 1 and 2.

4. Will the effects as indicated in points 2 and 3 also lead to a reduction of the number of traffic accidents and to the mitigation of their severity?

For this purpose all traffic accidents (including accidents with material damage only) will be analysed in the before- and after-period.

5. Will the reconstruction measures reduce the number of traffic accidents on the four specified "black spots"?

For this purpose, in addition to an accident evaluation, analyses will be carried out by the Swedish conflict observation technique on three of the four black spots, recording and processing conflict-implying behaviour of all traffic participants in the before- and after-period.

FIGURES 1-7

Figure 1. The traffic hump recommended by the Study Centre for Traffic Engineering SVT (Source: SVT, 1979).

Figure 2. Relation between speeds and distances with humps.

Figure 3. Schematic representation of the Floating Car-System.

Figure 4. Example of a serious conflict between a car from the minor road and cyclist 1. Bottom right: TTC curve.

Figure 5. Some vehicle characteristics used in calculating TTC curves.

Figure 6. Type of encounters

Figure 7. Five basic types of traffic situations

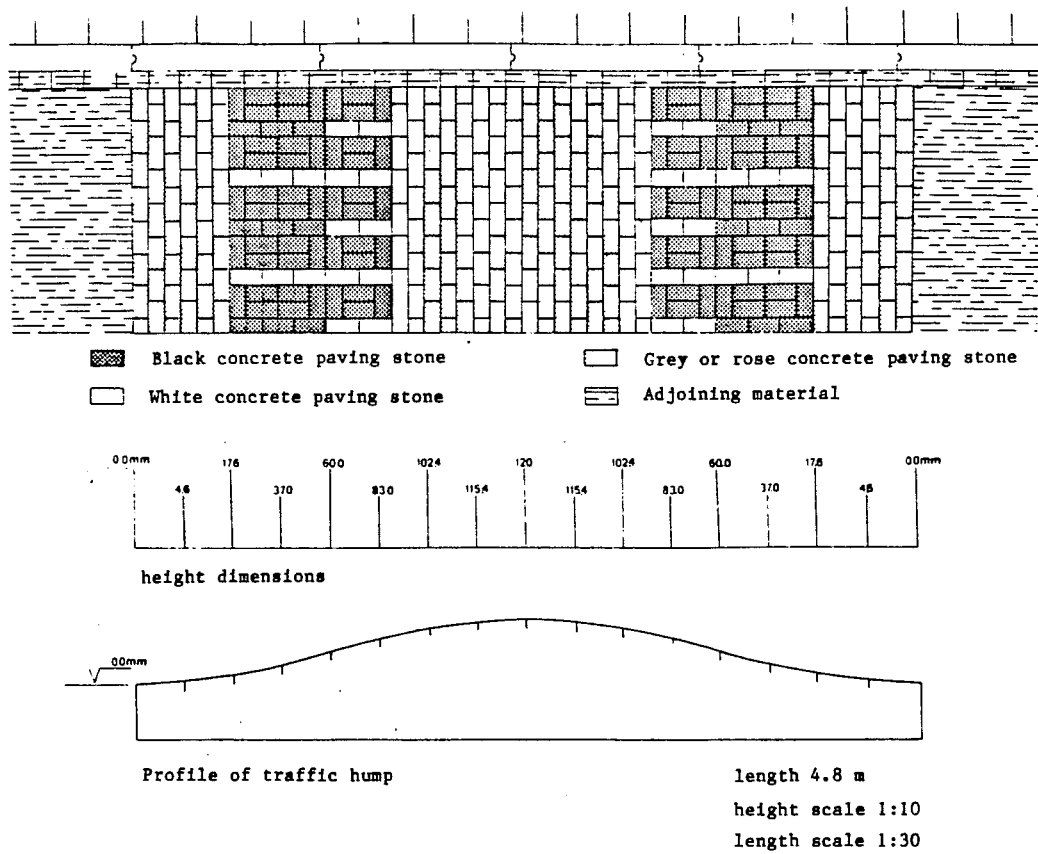

Figure 1. The traffic hump recommended by the Study Centre for Traffic Engineering SVT (Source: SVT, 1979).

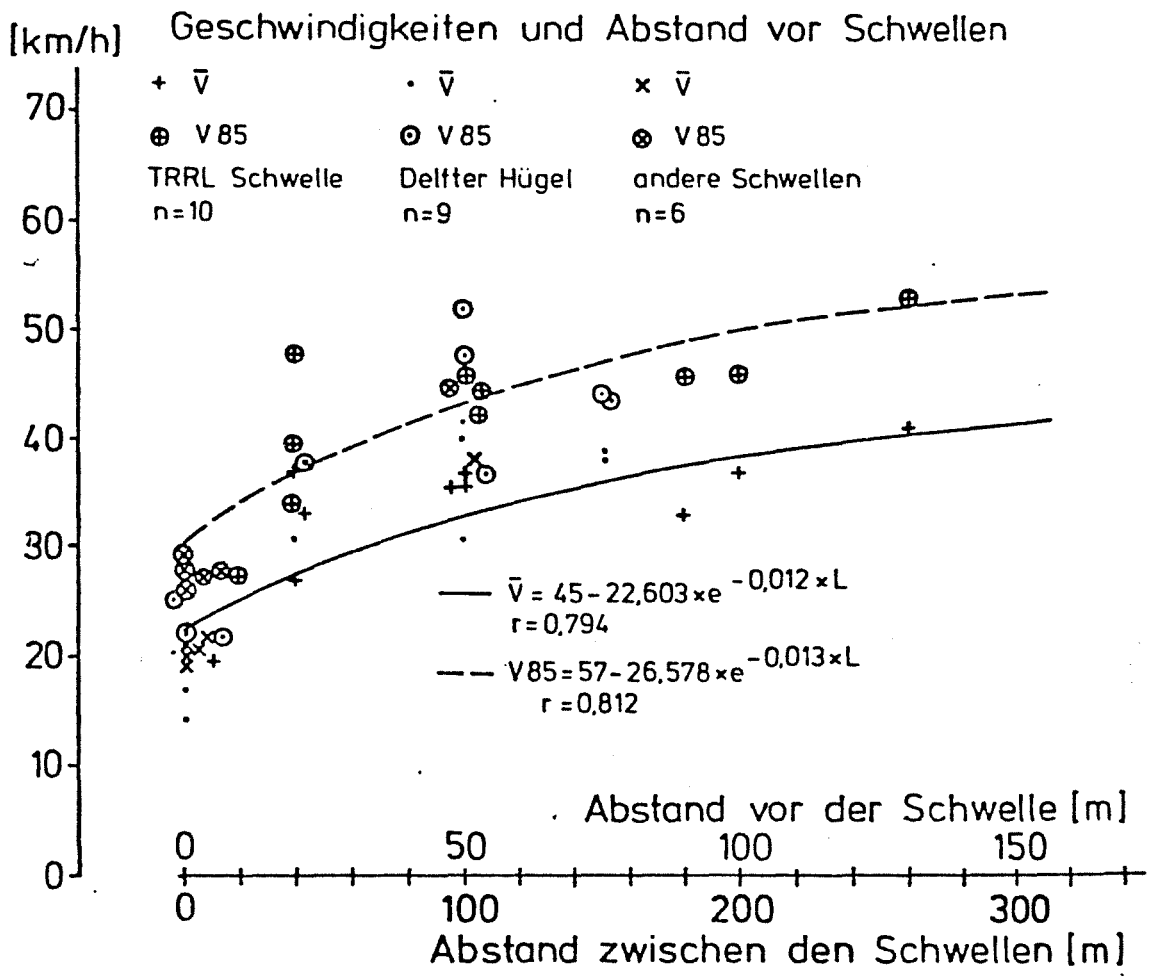

Figure 2. Relation between speeds and distances with humps.

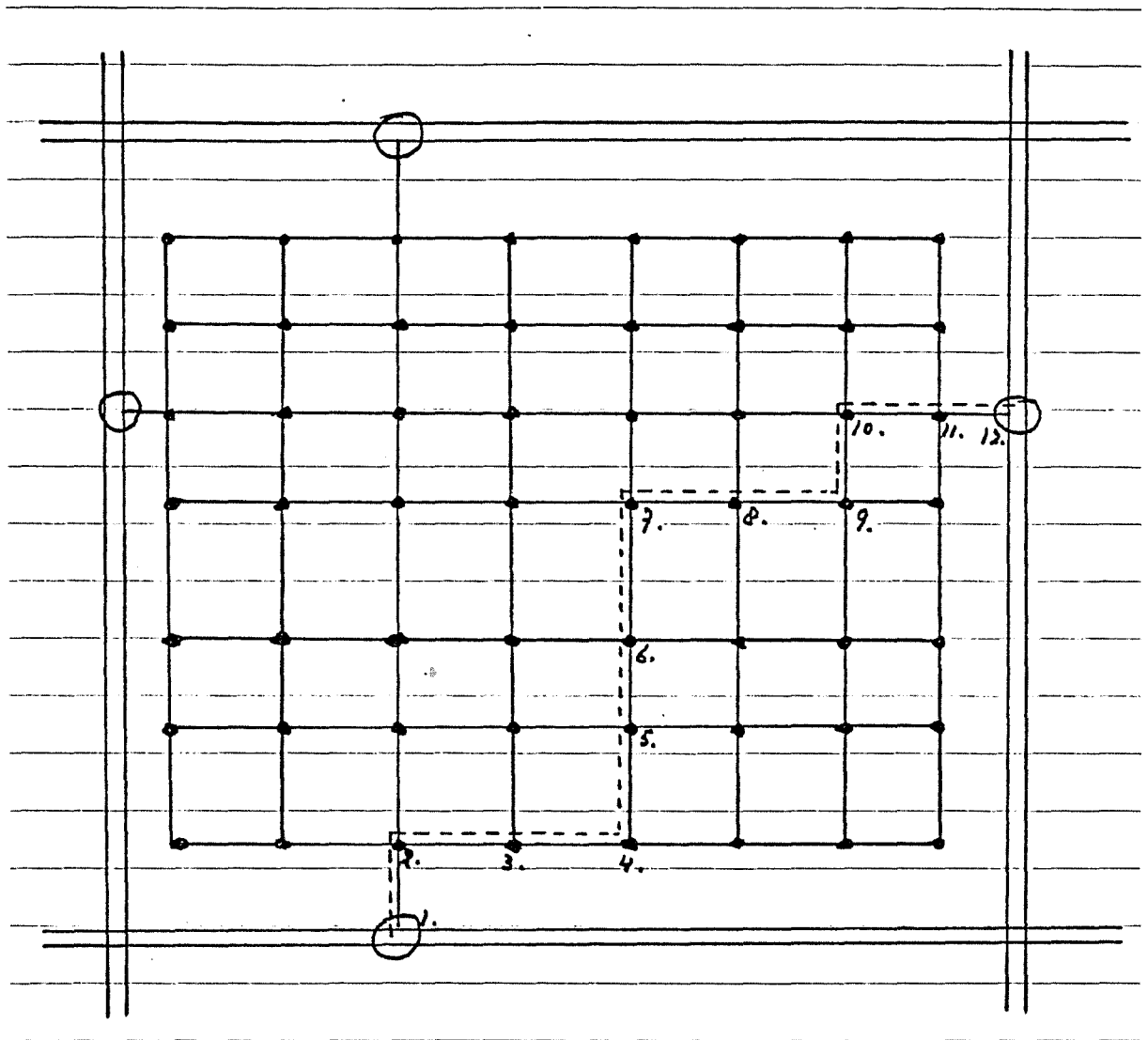

Figure 3. Schematic representation of the Floating Car-System.

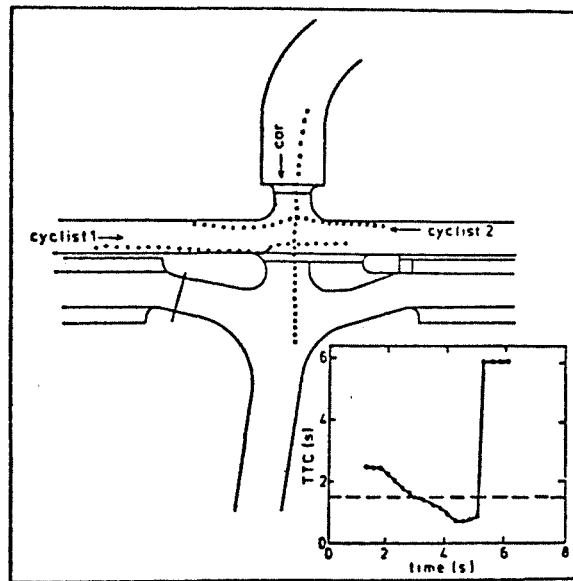

Figure 4. Example of a serious conflict between a car from the minor road and cyclist 1. Bottom right: TTC curve.

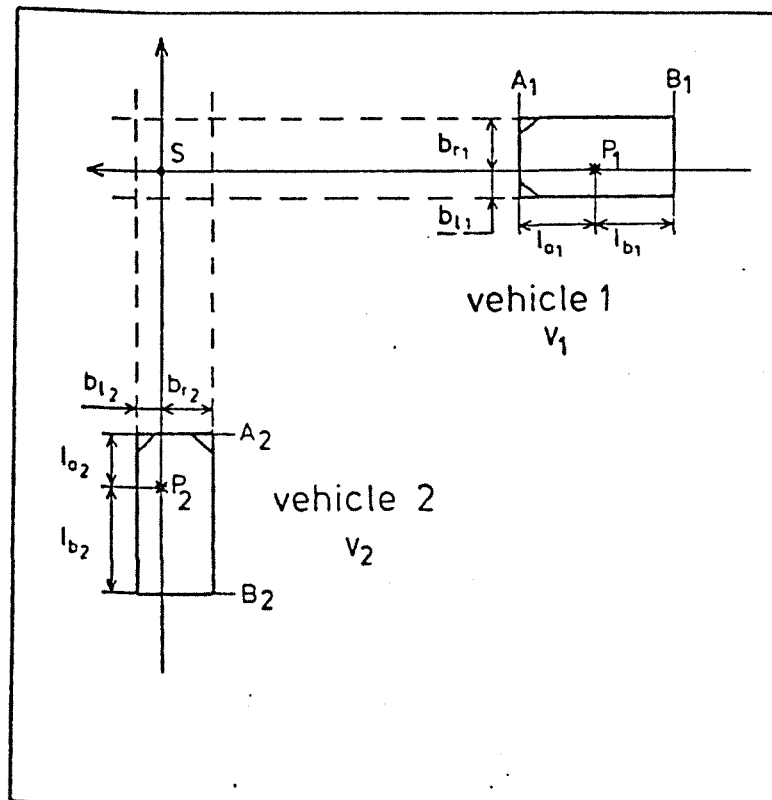
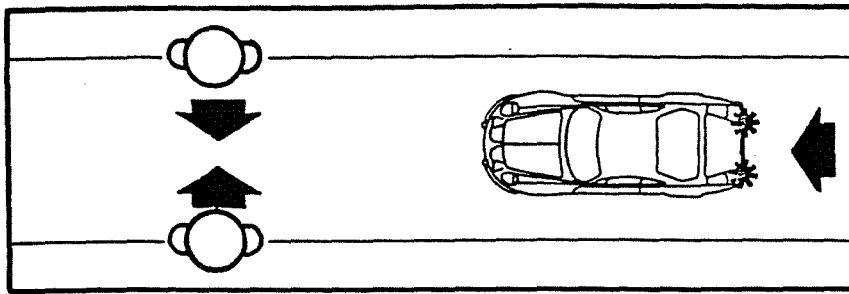

Figure 5. Some vehicle characteristics used in calculating TTC curves.

TYPES OF ENCOUNTERS

- 1. Serious conflict: a sudden motor reaction by a party, or both of the parties involved in a traffic situation towards the other, with a distance of about 1 metre or less between those involved.**
- 2. Conflict: a sudden motor reaction by a party, or both of the parties involved in a traffic situation towards the other, with a distance of about 2 metres or more (maximum 20 metres) between those involved.**
- 3. Intensive contact/conflict: a motor reaction between a sudden and non-sudden reaction by a party, or both of the parties involved in a traffic situation towards the other, with a distance of about 1 metre or less between those involved.**
- 4. Contact/conflict: a motor reaction between a sudden and non-sudden reaction by a party, or both of the parties involved in a traffic situation towards the other, with a distance of about 2 metres or more (maximum 20 metres) between those involved.**
- 5. Intensive contact: a non-sudden motor reaction by a party, or both of the parties involved in a traffic situation towards the other, with a distance of about 1 metre or less between those involved.**
- 6. Contact: a non-sudden motor reaction by a party, or both of the parties involved in a traffic situation towards the other, with a distance of about 2 metres or more between those involved.**

Figure 6. Types of encounters



Type 1
Traffic brakes
and may stop

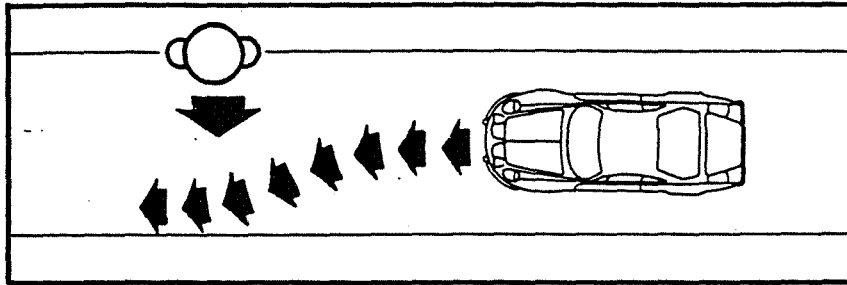

Type 2
Traffic changes
track

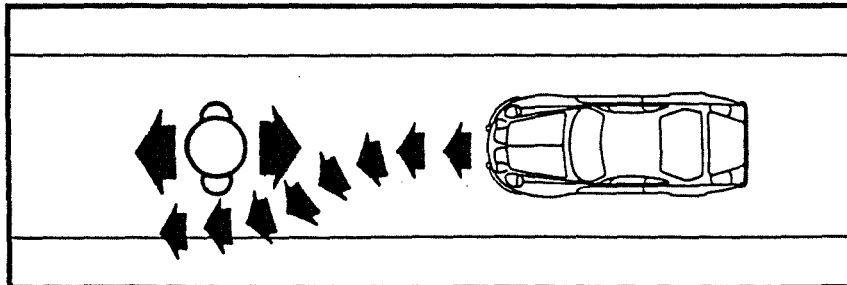

Type 3
Traffic changes
track. Pedestrian
walking, standing,
sitting on street.

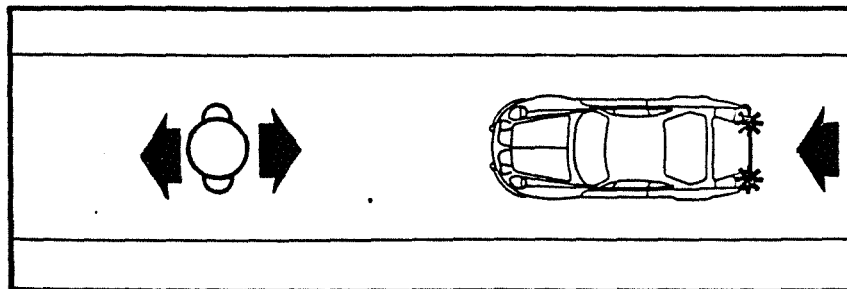

Type 4
Traffic brakes
and may stop.
Pedestrian walking,
standing, sitting
on street.

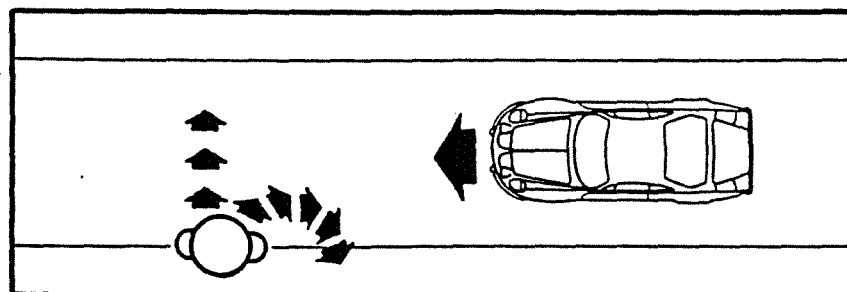

Type 5
Pedestrian crosses
rapidly or turns
back.

Figure 7. Five basic types of traffic situations

TABLES 1-4

Table 1. Distribution of traffic deaths within built-up areas over various modes of traffic participation in 1970-1982.

Table 2. Effect of traffic humps on traffic safety in five English towns (source: Sumner & Baguley, 1979).

Table 3. Survey of the 30 km/hr districts, which had been accepted in principle.

Table 4. Number of traffic accidents, broken down according to year, severity and the traffic category in the area "de Vliert" 's Hertogenbosch.

Year	Total within built-up areas	Passenger car %	Lorry %	Motor+ scooter %	Moped %	Bicycle %	Pedes- trian %	Rest %
1970	1319	23.3	1.9	2.0	21.4	20.5	30.1	0.9
1971	1286	22.0	1.2	2.5	23.3	23.6	27.1	0.3
1972	1322	21.7	1.4	2.8	22.0	23.1	28.4	0.7
1973	1277	24.0	1.2	3.0	21.5	22.4	27.3	0.7
1974	1065	21.0	1.4	3.7	20.8	25.4	27.1	0.6
1975	897	22.2	0.7	4.2	17.6	25.1	29.4	0.8
1976	956	25.5	0.8	4.2	13.3	27.5	28.2	0.5
1977	933	24.9	1.1	4.5	14.7	28.1	25.7	1.1
1978	845	24.1	0.6	5.0	13.7	29.0	26.4	1.2
1979	738	28.0	0.9	6.8	9.8	28.2	25.1	1.2
1980	813	25.7	0.9	6.4	11.1	29.1	25.9	0.9
1981	715	23.8	0.7	6.8	10.9	29.8	27.3	0.7
1982	664	25.0	0	5.9	7.2	33.0	27.7	1.2

Table 1. Distribution of traffic deaths within built-up areas over various modes of traffic participation in 1970-1982.

Number of injured per year						
in streets with humps		on adjacent inter- sections			in surrounding streets	
expected	actually without humps	expected with humps	actually without humps	expected with humps	actually without humps	with humps
Oxford	2.6	0	6.8	1	20.3	34
Norwich	1.6	0	0	0	10.4	9
Haringey	2.5	0	2.3	1	60.2	58
Kensington	2.2	1	7.0	7	35	30
Glasgow	1.2	1	1.7	0	4.1	12
Total	10.1	2	17.8	9	130	143

Table 2. Effect of traffic humps on traffic safety in five English towns (source: Sumner & Baguley, 1979).

Region	Area	30 ha	30 - 60 ha	60 ha	Number
<u>North</u>					
Groningen		Leeuwarden (19)	Zuidlaren (40)	Groningen (62)	4
Friesland		('t Heechterp)	(Westlaren)	(Hoogkerk)	
Drenthe			Zuidwolde (34) (Zuidwolde Oost)		
<u>East</u>					
Overijssel		Heerde (20)	Deventer (43)		3
Gelderland		(Molenkampjes)	(Landsheerkwartier)		
IJsselmeerpol.			Ede (34) (Lunteren)		
<u>South</u>					
Limburg		Loon op Zand (20)	Uden (46)	Heerlen (60)	5
N.Brabant		(Gerlandstr. e.o.)	(Instrumentenbuurt)	(Mariagewanden)	
<u>West</u>					
N.Holland		Amsterdam	Middelburg (37)		5
Z.Holland		(Cremerbuurt)	(Stromenwijk)		
Utrecht		Delft (16)	Amstelveen (35)		
Zeeland		(Poptahof)	(Elswijk oost) Utrecht (40) (Tuindorp)		
Number		5	8	2	15

(...) = number of districts to be included in the group.

Names between brackets: districts in the cities mentioned.

Table 3. Survey of the 30 km/hr districts, which had been accepted in principle.

Year	Number of accidents	Number of accidents with			Number of victims		
		deaths	lethal	material damage only	Moped	Bicycle	Pedestrian
1979	30	-	5	25	4	2	-
1980	27	-	3	24	2	3	1
1981	20	-	3	17	1	3	1
1982	22	-	3	19	4	2	-
Total	99 ¹⁾	-	14	85	11	10	2

1) 63 of the 99 accidents on intersections, among which 8 with lethal outcome

Table 4. Number of traffic accidents, broken down according to year, severity and the traffic category in "de Vliert" the area 's Hertogenbosch.